

SpeedTouch™

610/610i/610s/610v

Business DSL Router

Orientation Guide



SpeedTouch™ 610

Orientation Guide

Status Released
Change Note PeckelbeenS
Short Title CD-UG ST610 R4.1
Copyright

© 2002 THOMSON multimedia. All rights reserved. Passing on, and copying of this document, use and communication of its contents is not permitted without written authorization from THOMSON multimedia. The content of this document is furnished for informational use only, may be subject to change without notice, and should not be construed as a commitment by THOMSON multimedia. THOMSON multimedia assumes no responsibility or liability for any errors or inaccuracies that may appear in this document.

Contents

1	SpeedTouch™ 610 Installation	3
1.1.	Get Acquainted with the SpeedTouch™ 610	4
1.2.	SpeedTouch™ 610 Wiring	8
1.3.	SpeedTouch™ 610 Configuration Setup	11
1.3.1.	Configuration Setup for MS Windows OSs	12
1.3.2.	Configuration Setup for other OSs	16
1.4.	SpeedTouch™ 610 Internet Connectivity	17

2	The SpeedTouch™ 610 Web Interface.....	19
2.1.	General Principles.....	20
2.2.	Quick Tasks Links	23
2.3.	IP Router Tasks Links.....	26
2.4.	Connection Tasks Links.....	31
2.5.	LAN Services Tasks Links	36
2.6.	System Config Tasks Links.....	39
2.7.	Advanced Tasks Links.....	43

3	SpeedTouch™ 610 Advanced Concepts	45
3.1.	Native Command Line Interface Access.....	46
3.2.	Simple Network Management Protocol	48

4 Troubleshooting 49

1 SpeedTouch™610 Installation

Introduction

Thank you for purchasing the SpeedTouch™610 Business DSL router !

Specially designed for Small/Medium Enterprises (SMEs) and Small Office/Home Office (SOHO), the SpeedTouch™610 Business Digital Subscriber Line (DSL) router offers plenty of capabilities. With an easy installation, embedded firewall, embedded IPSec based IP Virtual Private Networking (VPN) and remote management tools, the SpeedTouch™610 is a highly secure device.

Beyond the small business market, the SpeedTouch™610 is the ideal solution for connecting regional and branch offices back to corporate headquarters.

In this Orientation Guide

This Orientation Guide will assist you in getting acquainted with the SpeedTouch™610 Business DSL router and its broad range of service capabilities.

Documentation and software updates

Due to the continuous evolution of DSL technology, existing products are regularly upgraded.

For more information on the newest technological breakdowns, software upgrades, and documents, please consult the SpeedTouch™ web sites at:

- <http://www.speedtouch.com>

1.1. Get Acquainted with the SpeedTouch™610

Delivery check Check your SpeedTouch™610 box for the following items:

- The SpeedTouch™610/610i/610s/610v
- One power adapter
- One Cat.5 straight-through Ethernet cable (RJ45/RJ45)
- One DSL cable (RJ11/RJ11, RJ14/RJ14)
- Optionally, one or more cable filter(s)
- The SpeedTouch™610 Quick Installation Guide (eight languages)
- The SpeedTouch™610 Orientation Guide (English only)
- The SpeedTouch™ Setup CD-rom.

In the event of damaged or missing items, contact your product dealer for further instructions.

Other materials The SpeedTouch™610 box may also include other materials.

The Setup CD-Rom The Multi-OS SpeedTouch™ Setup CD-rom includes:

- The SpeedTouch™ Setup wizard (for MS Windows OSs only)
- SNMP MIBs,
- Adobe Acrobat Reader installation software
- One or more configuration profile files
- The SpeedTouch™610 Quick Installation Guide (PDF format)
- The SpeedTouch™610 Orientation Guide (PDF format)
- SpeedTouch™ Application Notes (PDF format)
- Technical papers, white papers (PDF format).

Additional software, promotional items, and documentation may be available on the CD-Rom.

Front and back panel layout

The SpeedTouch™610 is presented in a slimline housing:



Depending on the SpeedTouch™610 model you purchased, the device can be equipped with:

- One single 10/100Base-T Half-/Full-duplex MDI-X Ethernet port (optionally with one 25.6Mb/s ATM-Forum port):

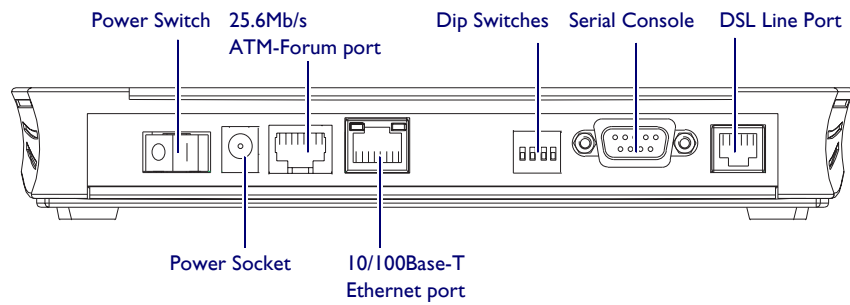

- A four port 10/100Base-T Half-/Full-Duplex auto-MDI/MDI-X Ethernet switch:

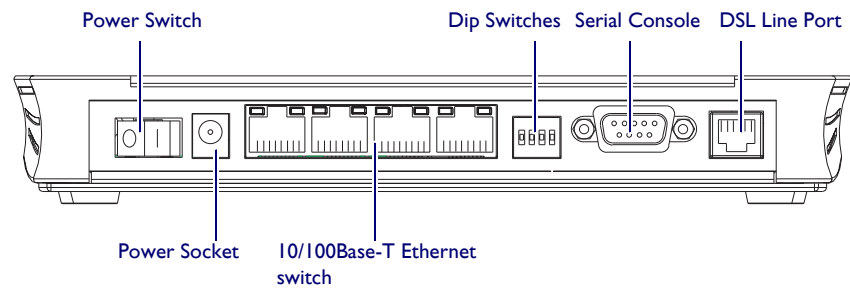

Front panel LEDs

The SpeedTouch™ 610 is equipped with 5 LEDs on its front panel, indicating the state of the device during normal operation:

Indicator			Description
Name	Color	State	
LAN	Green	Flashing	Ethernet LAN activity.
		Off	No Ethernet LAN activity.
Line TX	Green	Flashing	ATM cell transmission on DSL line.
		Off	No transmission activity.
Line RX	Green	Flashing	ATM cell reception on DSL line.
		Off	No reception activity.
Line Sync	Green	Flashing	Initialization of DSL line.
		On	DSL line synchronized.
PWR/Alarm	Green	On	Power on, normal operation.

Ethernet port(s) LEDs

The back panel contains the following:

- The DC power inlet and power switch
- One or four 10/100Base-T Ethernet port(s)
- Optionally, the 25.6Mb/s ATM-Forum port
- Reset DIP switches
- Serial Console port
- The DSL Line port.

Each Ethernet port on the rear panel has two LEDs:

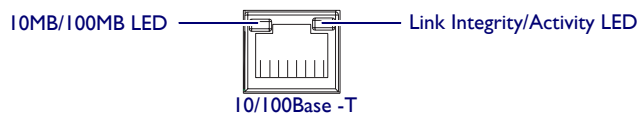

Indicator			Description
Name	Color	State	
10MB/100MB	Green	Off	10Base-T Ethernet connectivity
		On	100Base-T Ethernet connectivity
Integrity Activity	Green	Off	No connection on this port.
		On	Ethernet link up. No activity.
		Flashing(*)	Activity on this Ethernet port.

DSL variants Four DSL variants of the SpeedTouch™610 Business DSL routers exist:

- The SpeedTouch™610 :
The ADSL/POTS variant connecting to an analog POTS(*) line
- The SpeedTouch™610i :
The ADSL/ISDN variant connecting to a digital ISDN(**) line
- The SpeedTouch™610s :
The SHDSL variant connecting to a dedicated SHDSL(***) line
- The SpeedTouch™610v :
The SHDSL variant connecting to a dedicated VDSL(***) line

(*) Plain Old Telephone Service (POTS)

(**) Integrated Services Digital Network (ISDN)

(***) Symmetrical High speed Digital Subscriber Line (SHDSL)

(***) Very high speed Digital Subscriber Line (VDSL)

Use only the SpeedTouch™610 variant which is appropriate for the DSL service delivered to your local premises.

Check at your Service Provider whether your SpeedTouch™610 variant meets the DSL service requirements.

DSL service The appropriate DSL service must be available at your local premises:

- ADSL, SHDSL or VDSL service must be enabled on your phone line
- In case of ADSL, both POTS or ISDN and ADSL service are simultaneously available from the same copper pair. Therefore, you need a central splitter or distributed filters for decoupling ADSL and telephone signals.

Always contact your Service Provider for splitter/filter installation !

Public telephone lines carry voltages that can cause electric shock. Only install splitter/filters yourself if they have been designed to be installed by unqualified personnel. Other splitter/filters may only be installed by qualified service personnel.

1.2. SpeedTouch™610 Wiring

- Local network For Ethernet connectivity you need at least:
- A computer with installed Ethernet Network Interface Card (NIC)
 - If needed, a hub or switch and the necessary connection cables.

Ethernet Cables In the SpeedTouch™610 box, a full wired Cat.5 straight-through RJ45/RJ45 Ethernet cable, further referred to as LAN cable is included.

You can use LAN cables other than the one provided in the box. However make sure to use correct connection cables.

Wiring procedure Proceed as follows:

Step	Action
1	Use the included LAN cable to wire your computer's Ethernet port to (one of) the SpeedTouch™610 Ethernet port(s).
2	For local networking, repeat step 1 for each computer. Note: If an additional hub or switch is used, please follow the installation instructions supplied with the hub or switch.
3	Use the included DSL cable to wire the SpeedTouch™610's Line port to your telephone/DSL service wall outlet.
4	Plug the power adapter's coaxial jack into the SpeedTouch™610 DC inlet. Note: Always check first whether the included power adapter suits the local power specifications.

More information on Ethernet wiring For more information, see the application note “The SpeedTouch™ and Ethernet Connectivity”.

Single PC wiring

Once all connections are made the result should look similar as below.

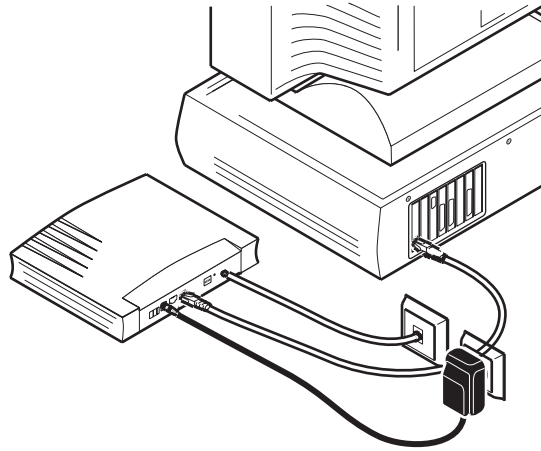

LAN wiring

Using the SpeedTouch™610 switch (if equipped) and/or an external hub you can connect multiple PCs to your SpeedTouch™610:

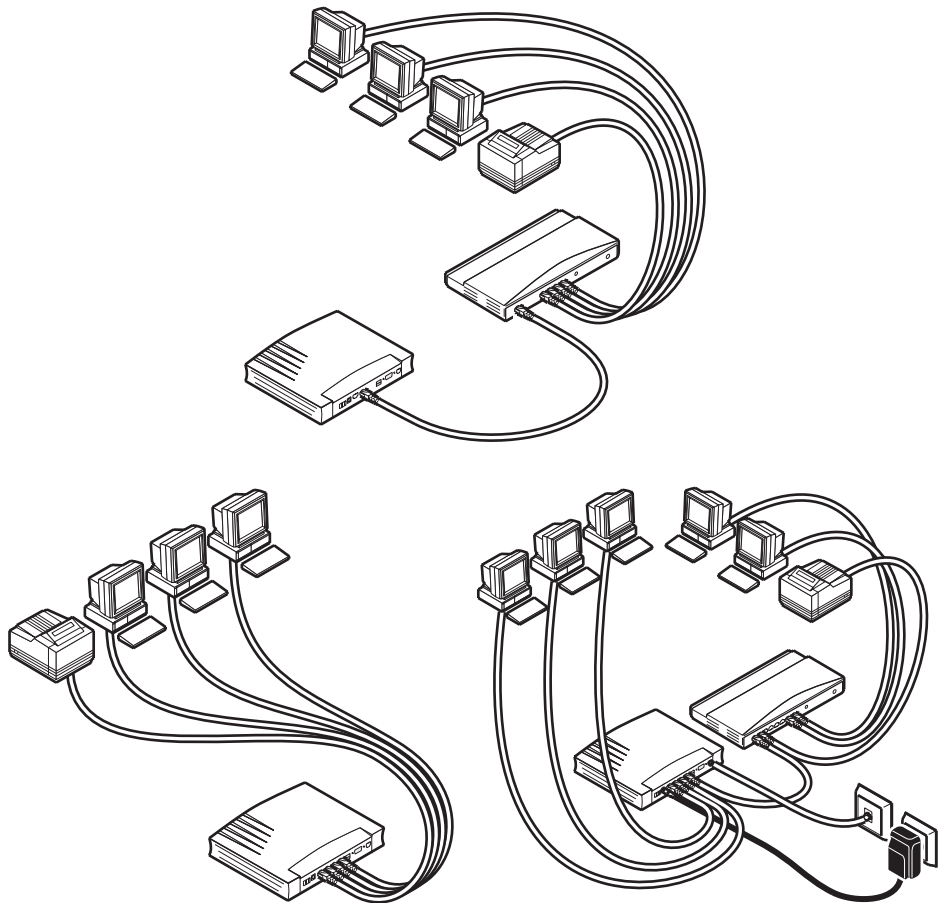

Powering Once all previous steps are completed, you can turn the SpeedTouch™610 on (I) with the power switch.

POST phases As soon your SpeedTouch™610 is turned on, you can check the “PWR/Alarm” LED to see how the Power On Self Test (POST) progresses.

Phase	“PWR/Alarm” LED Indication	Description
1	Flashing red	POST pending
2	Solid red	Start-up failed
		POST failed
	Solid green	Normal operation

1.3. SpeedTouch™610 Configuration Setup

Internet connectivity

As soon as the SpeedTouch™610 is installed as described in section “1.2. SpeedTouch™610 Wiring” on page 8 the SpeedTouch™610 can be prepared for Internet connectivity.

The configuration of your SpeedTouch™610 can be done semi-automatically via the SpeedTouch™ Setup configuration files (available on the SpeedTouch™ Setup CD-rom), or manually via its web pages.

This section exclusively describes how to configure the SpeedTouch™610 via the Setup configuration files. For advanced configurations via the SpeedTouch™610 web pages, check chapter “2 The SpeedTouch™610 Web Interface” on page 19, that gives an overview of all the web pages and the relevant application notes.

What you need from your SP

You must have a user account with an Internet Service Provider (ISP) for Internet access. For this user account, it will provide you with:

- A user name (logon ID)
- A password.

Other information might be required depending on the provided CD-rom and/or specific requirements of the ISP.

SpeedTouch™ configuration options

The method for configuring the SpeedTouch™610 via the Setup configuration files depends on the Operating System (OS) of your computer system.

In case your computer system runs:

- A Microsoft Windows OS

From the included SpeedTouch™ Setup CD-Rom a wizard will automatically guide you through the configuration of both the SpeedTouch™610 and your PC(s) for setting up the appropriate configuration.

Proceed with subsection “1.3.1. Configuration Setup for MS Windows OSs” on page 12.

- Another OS, e.g. Mac OS, Unix, Linux, etc.

The configuration of the SpeedTouch™610 is done via uploading the appropriate Setup configuration file from the included SpeedTouch™ Setup CD-Rom to your SpeedTouch™610.

If needed, additional configuration of your computer(s) must be done manually.

Proceed with subsection “1.3.2. Configuration Setup for other OSs” on page 16.

1.3.1. Configuration Setup for MS Windows OSs

Microsoft Windows

One of the following OSs must be installed on your PC(s):

- Microsoft Windows 95
- Microsoft Windows 98 or 98SE
- Microsoft Windows ME
- Microsoft Windows NT4.0
- Microsoft Windows 2000
- Microsoft Windows XP.

You may need the Windows installation CD-rom during installation.

TCP/IP

Make sure that TCP/IP (*) is installed on your PC(s).

(*) Transmission Control Protocol (TCP) / Internet Protocol (IP)

The SpeedTouch™ Setup Wizard

The SpeedTouch™ Setup wizard can be divided into two parts:

- The detection procedure
- The configuration procedure.

The detection procedure

Step	Action
1	<p>Insert the SpeedTouch™ Setup CD-rom in your PC's CD-rom drive. The wizard will start automatically.</p> <p>Note: In case the wizard does not start automatically, open a 'Run' window via Start > Run from the Start menu and enter following path: D:\SetupST.exe, where D is the drive letter of your CD-rom drive.</p>
2	<p>The SpeedTouch™ Welcome wizard pops up:</p>  <p>To start the SpeedTouch™ Setup wizard, click SPEED TOUCH Setup.</p>

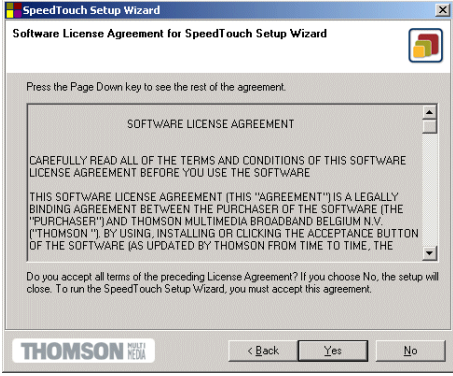
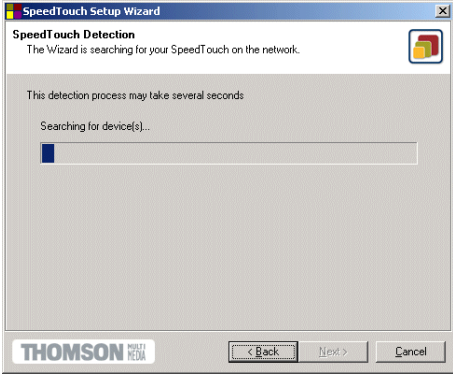
Step	Action
<p>3</p>	<p>The Welcome to the SpeedTouch™ Setup Wizard window pops up:</p>  <p>Click Next to proceed.</p>
<p>4</p>	<p>The Software License Agreement for SpeedTouch™ window pops up:</p>  <p>Click Yes to accept the terms of the agreement and to continue with the Setup wizard.</p>
<p>5</p>	<p>The Setup wizard will continue by searching for the SpeedTouch™610 on the network. The following window shows the detection progress:</p> 

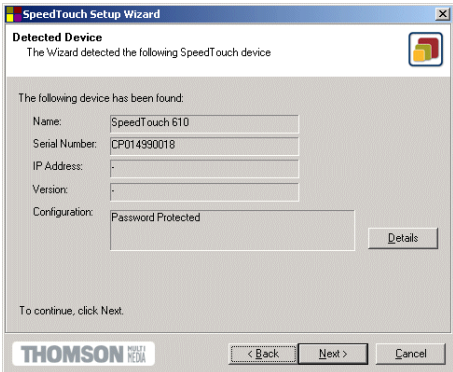
Step	Action
<p>6</p>	<p>The setup wizard should find your SpeedTouch™610 device on the local network. This is indicated by following window:</p>  <p>If the wizard does not find a SpeedTouch™610 on the network an error window pops up. In this case check that:</p> <ul style="list-style-type: none"> • Your PC is correctly wired to the SpeedTouch™610 • No dedicated firewall device or a router is placed between your PC and the SpeedTouch™610 and that no personal firewall software is running on your PC • The SpeedTouch™610 is powered on and fully initialized • TCP/IP is correctly installed on your PC, and that your PC is configured with a valid IP address(*). <p>To retry the detection of the SpeedTouch™610, click Back and repeat step 5 of this procedure.</p> <p>(* In case of MS Windows 95 or Windows NT4.0 it is advised to configure the PC with a static IP address, e.g. 10.0.0.101, which is unique (in case of a local network). Make sure however not to use the 10.0.0.138 IP address as it is the SpeedTouch™610's default IP address. For MS Windows 98, 98SE, ME, 2000 and XP OSs it is advised to configure the PC as a DHCP client. Refer to the MS Windows user documentation for more information.</p>
<p>7</p>	<p>To continue with the configuration of your SpeedTouch™610 and your PC, proceed with the configuration procedure described below</p>

The configuration procedure

Step	Action
<p>1</p>	<p>As soon the wizard detected your SpeedTouch™610 some device details are shown. In case multiple SpeedTouch™ devices reside on your local LAN a listing of devices is shown from which you can select the appropriate one. Click Next to proceed.</p> <p>Note: If the SpeedTouch™610 has been configured before, it may be protected by a System password. Before you are able to overview the device details or continue with the configuration this password has to be entered.</p>

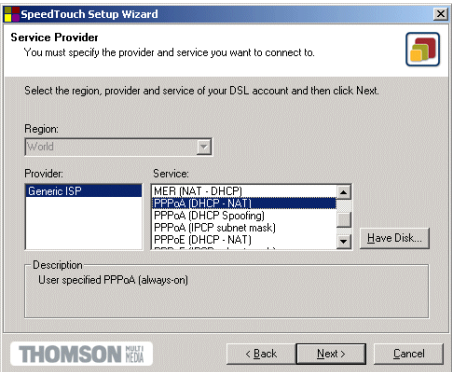
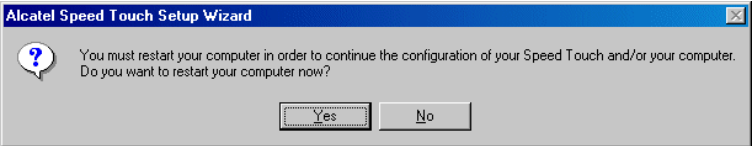
Step	Action
<p>2</p>	<p>The following window invites you to select the appropriate connection profile for your Internet connectivity:</p>  <p>Select the connection profile and click Next to continue.</p> <p>Note: In case the Service Provider included a separate disk with a dedicated connection profile, click Have Disk to navigate to the location of the appropriate connection profile file.</p>
<p>3</p>	<p>Subsequent screens will guide you through the configuration setup of both the SpeedTouch™610 and/or your PC. Follow the instructions and enter the required information where needed. This information should be provided by your Service Provider.</p> <p>Click Next each time to continue.</p>
<p>4</p>	<p>After configuring the SpeedTouch™610 it will restart. In some cases your PC must be restarted as well for the changes to take effect:</p> 
<p>5</p>	<p>At reboot of your PC the wizard will automatically pop up once more to announce that the configuration procedure has been successfully completed.</p> <p>Click Finish to close the wizard.</p>
<p>6</p>	<p>If multiple PCs on your local network need to be configured to enable access to the SpeedTouch™610 you can either:</p> <ul style="list-style-type: none"> • Re-run the SpeedTouch™ Setup wizard on every PC <p>Or, if applicable:</p> <ul style="list-style-type: none"> • Enable automatic IP address configuration (DHCP client) on every PC.

1.3.2. Configuration Setup for other OSs

Supported OSs As the SpeedTouch™610 is OS independent, this configuration setup can be used by any computer system

Note: In fact the following procedure may equally be used on MS Windows OSs for configuring the SpeedTouch™610.

TCP/IP Make sure that TCP/IP is installed on your computer(s).
Configure every PC with a static Net10 private IP address, e.g. 10.0.0.1, 10.0.0.2, etc. Make sure though NOT to use the 10.0.0.138 IP address as this is the default IP address of the SpeedTouch™610.

To test IP connectivity, ping the SpeedTouch™610.

Procedure

Step	Action
1	To make sure that the SpeedTouch™610 is in its factory default state, perform a reset to defaults. For more information, see the application note “Speed-Touch™ Operation and Maintenance”.
2	Open a web browser and browse to the SpeedTouch™610's default IP address 10.0.0.138. See chapter “2 The SpeedTouch™610 Web Interface” on page 19 for more information.
3	Click Upgrade in the System Config Menu to open the Upgrade web page.
4	In the Configuration window, click Browse next to the Configuration file path input field to locate the configuration file on the CD-rom or disk. Note: If the path is known you can immediately enter it in the Configuration file path input field.
5	Click Upload to start the upload.
6	Click Restart to restart the SpeedTouch™610 and activate the uploaded configuration.
7	After restarting the SpeedTouch™610 some additional configuration of your computer system might be needed. Note: The required settings for your computer should be provided by your Service Provider, if applicable.
8	To check whether the activation of the uploaded configuration was successful, you can browse to the SpeedTouch™610 and overview the current configuration.

1.4. SpeedTouch™610 Internet Connectivity

Surfing the Internet

As soon as the SpeedTouch™610 and the computer(s) are configured as described in the previous section, you are able to establish connectivity to the Internet.

Connection Services and Packet Services

The SpeedTouch™610 supports various scenarios to establish end-to-end connectivity with the BroadBand Remote Access Server (BBRAS) and the Internet.

For more information, see the application note “SpeedTouch™ Connection and Packet Services”.

The scenario to use depends on the configuration profile/file you used to configure the SpeedTouch™610 and the Service Provider's requirements.

Your Internet connection

Regardless of which scenario is used to make a connection, once it is established, opening your web browser is enough to access the World Wide Web (WWW).

Note: In some cases, e.g. in case of Transparent Bridging, the remote organization might ask for a user name and password on an Internet welcome page.

An example of how to establish a PPP dial-in connection via the SpeedTouch™610 embedded dial-in client is provided on the next page.

SpeedTouch™ web pages

Your SpeedTouch™610 offers a user-friendly web interface. Via the web pages you are able to establish dial-in connections, configure and use the advanced services such as VPN, SNTP, RIP, DNS and the web-CLI to name just a few, overview some device details and some DSL connection statistics, and upgrade device software and its configuration.



See chapter “2 The SpeedTouch™610 Web Interface” on page 19 for more information.

Example: Using the SpeedTouch™ PPP Dial-in

Via the SpeedTouch™610 web interface you are able to establish PPP (PPPoA or PPPoE) dial-in connections, configured by the SpeedTouch™ Setup wizard or by uploading the appropriate configuration file.

Note: The following provides only an example on how you can establish your Internet connection. The actual implementation depends on the preferences of your Service Provider.

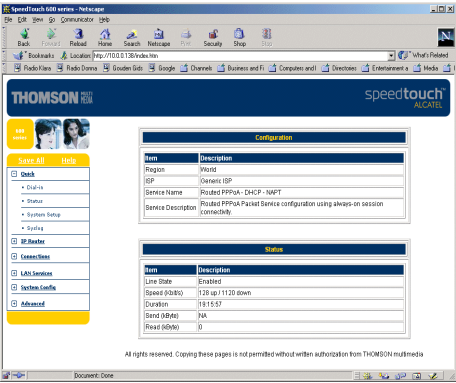
To open a dial-in connection:

Step	Action
<p>1</p>	<p>Open a web browser on your PC/computer and browse to the Speed-Touch™610 web pages:</p>  <p>By default the SpeedTouch™610 offers you the Configuration & Status page.</p>
<p>2</p>	<p>In the Quick Menu, click Dial-in to open the PPP Dial-in Connections page which enables you to establish dial-in connections.</p>
<p>3</p>	<p>Click  next to the connection entry you want to establish a connection with. As a result it will be highlighted.</p>
<p>4</p>	<p>Enter your user name and password in the appropriate fields. If you want the SpeedTouch™610 to remember your credentials, select 'Save password'.</p>
<p>5</p>	<p>If applicable, enter the appropriate Service name.</p>
<p>6</p>	<p>Click Dial-in. While the SpeedTouch™610 tries to open the session 'trying' will appear in the 'State' field. Once the session is active the field displays 'up'. You can start your application or browse the Internet. To close an active dial-in connection:</p>
<p>7</p>	<p>Make sure you have access to the SpeedTouch™610 web pages.</p>
<p>8</p>	<p>On the PPP Dial-in Connections page, click  next to the connection entry you want to close the connection for.</p>
<p>9</p>	<p>Click Hang-Up. As a result the session state of the entry will change to down, i.e. it becomes idle.</p>

2 The SpeedTouch™610 Web Interface

Introduction The SpeedTouch™610 comes with integrated local configuration capabilities. The local configuration via the SpeedTouch™610 web interface, is based on the HTTP server/Web browser concept. It allows configuration of your SpeedTouch™610 via a Web browser through HTML pages from any local PC attached to the Ethernet interface(s).

Preconditions Prior to access the SpeedTouch™610 web pages make sure that either:

- Your Web browser is not using a Proxy server
- The SpeedTouch™610 IP address is not submitted to a Proxy server.

For more information on how to disable your web browser's proxying, please consult the web browser's user documentation.

Use of the SpeedTouch™ web interface

In most cases the SpeedTouch™610 is correctly configured for your Internet connectivity via the appropriate configuration profile/file and no further configuration on the web interface is needed.

Only for using the advanced SpeedTouch™610 features, access to the web pages is required.

This chapter aims to give a brief overview of the SpeedTouch™610 web pages and their respective functionality.

For more profound information, see the relevant application notes.

2.1. General Principles

Procedure

Step	Action
1	Start the web browser on your PC or computer.
2	Contact the SpeedTouch™ 610 by entering its IP address (in most cases 10.0.0.138) in the URL field.
3	If a system password was set an authentication window will pop up. Enter a user name and the system password in the appropriate fields.

Result As a result the Welcome to the SpeedTouch™ 610 page pops up:

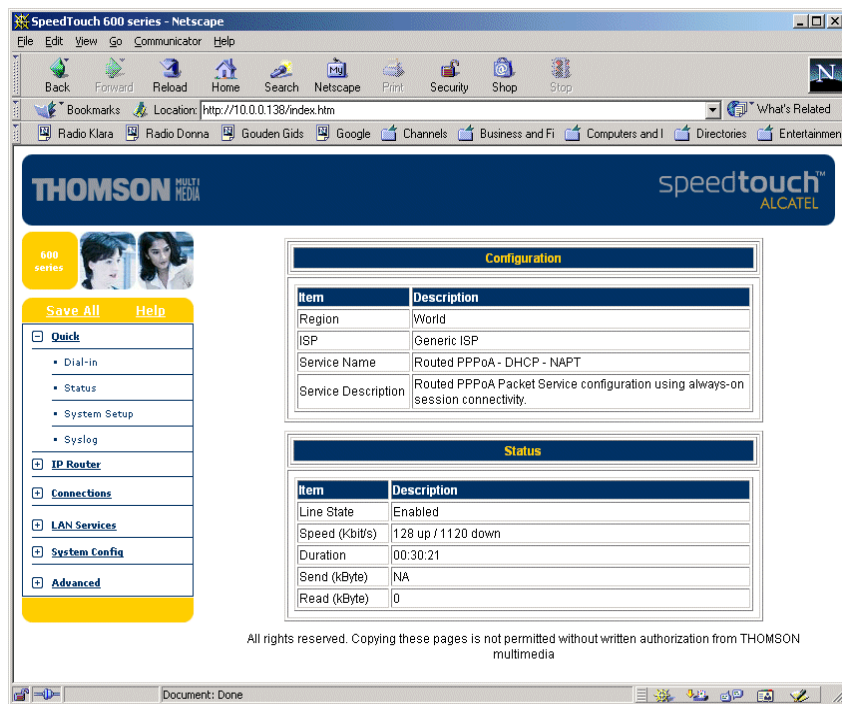

From now on the SpeedTouch™ 610 acts as a Web server sending HTML pages/forms at your request. You can fill out these pages/forms and submit them to the Speed-Touch™ 610. The latter scans the pages and makes configurations accordingly.

Topic links On each of the SpeedTouch™610 web pages the Tasks Menu offers you the following Configuration Places: Quick, IP Router, Connections, LAN Services, System Config, and Advanced. Each of these offers you a set of specific links, leading you to a configuration aspect of the SpeedTouch™610. The following table lists all these links:

Click ...	To ...
“2.2. Quick Tasks Links”	
“ Dial-in”	Establish dial-in PPPoA and/or PPPoE connections.
“ Status”	Overview current configuration profile. Overview current ADSL line status.
“ System Setup”	Provide a system password. Restore the default SpeedTouch™610 configuration.
“ Syslog”	Overview/configure Syslog services.
“2.3. IP Router Tasks Links”	
“ Static Routing”	Overview/configure IP interfaces and IP router.
“ RIP”	Overview/configure RIP services.
“ NAPT”	Overview/configure NAPT services. Define a Default local server for inbound connectivity.
“ IPSec/VPN”	Overview/configure IPSec based VPN services.
“2.4. Connection Tasks Links”	
“ Phonebook”	Overview/configure connection service entries.
“ PPP”	Configure Routed PPPoA and Routed PPPoE.
“ MER”	Configure Routed Ethernet.
“ IPoA”	Configure Routed IPoA.
“ CIP”	Configure Routed Classical IPoA.
“ Bridging”	Configure Bridged Ethernet (for Bridged PPPoE).
“ PPTP”	Overview current Relayed PPPoA connections.
“2.5. LAN Services Tasks Links”	
“ DHCP”	Overview/configure DHCP services.
“ DNS”	Overview/configure DNS services.
“2.6. System Config Tasks Links”	
“ Initial Setup”	Specify a user defined IP address and netmask.
“ System Setup”	Provide a system password. Restore the default SpeedTouch™610 configuration.
“ Upgrade”	Manage software and configuration.

Click ...	To ...
“ Add-On”	Manage software keys.
“ SNTP”	Overview/configure SNTP services.
“ Syslog”	Overview/configure Syslog services.
“2.7. Advanced Tasks Links”	
“ CLI”	Open the web based Command Line Interface.

**Saving
SpeedTouch™610
settings**

The Save All link on the tasks menu allows you to save the SpeedTouch™610 settings to memory. It is advised to back-up your saved configuration on a regular basis. This can be done via the Upgrade link in the System Config configuration place.

Help

The Help link on the tasks menu and the Help links on the configuration pages provide context related Help web pages.

2.2. Quick Tasks Links

Dial-in Clicking this button pops up the PPP Dial-in Connections page.

This page allows to:

- Establish dial-in connections, if applicable:

PPP Dial-in Connections		
Interface	Destination	State
RtPPPoE	RtPPPoE	down
RtPPPoA	RtPPPoA	down

Dial-in Hang-Up

See section “1.4. SpeedTouch™ 610 Internet Connectivity” on page 17 for more information on how to use the Dial-in Connections table.

For more information on the configuration and use of PPP connections, see the application notes “The SpeedTouch™ Routed PPPoA Packet Service” and “The SpeedTouch™ Routed PPPoE Packet Service”.

Status Clicking this link pops up the Configuration & Line Status page. This page is also the SpeedTouch™ 610 “home” page.

It allows to:

- Overview which configuration profile/file is currently loaded, including information for which Region and ISP this configuration applies:

Configuration	
Item	Description
Region	World
ISP	Generic ISP
Service Name	Routed PPPoA - DHCP - NAPT
Service Description	Routed PPPoA Packet Service configuration using always-on session connectivity.

- Overview the current physical status of the ADSL line:

Status	
Item	Description
Line State	Enabled
Speed (kbit/s)	128 up / 1120 down
Duration	00:33:25
Send (kByte)	NA
Read (kByte)	0

System Setup Clicking this button pops up the System Setup page.

This page allows to:

- Configure a System password to restrict access to the SpeedTouch™610:



The screenshot shows a web form titled "System Setup". It contains two text input fields: "Password" and "Retype your password", both containing seven asterisks. Below the fields are two buttons: "Help" and "Apply".

It is highly advised to configure a System password. To protect the Speed-Touch™610 you should change the System password on a regular basis. However, never use an obvious password as your name, birth date, etc.

Enter the System password of your choice and re-enter it in the appropriate fields. Click Apply to apply the System password and Save All to save your changes to persistent memory.

Note: As long as no System password is supplied, a warning is displayed on the SpeedTouch™610 web pages.

- Reset the SpeedTouch™610 configuration to its default settings (IP configuration is maintained):

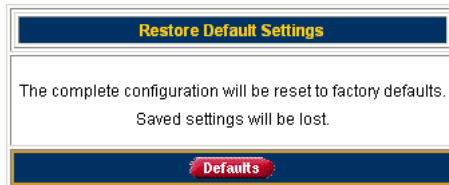

The screenshot shows a dialog box titled "Restore Default Settings". The text inside reads: "The complete configuration will be reset to factory defaults. Saved settings will be lost." At the bottom of the dialog is a button labeled "Defaults".

Click Defaults to initiate a reset of the complete configuration. A warning will be displayed, asking for configuration of the reset. Click OK if you are sure. Otherwise click Cancel.

Note: After reset, all original configurations of the SpeedTouch™610 are restored, except the SpeedTouch™610 IP Ethernet IP settings.

For more information regarding the SpeedTouch™610 security features, default settings, and configuration update, see the application note "SpeedTouch™610 Operation and Maintenance".

Syslog Clicking this button pops up the Syslog page.

This page allows to:

- Overview the syslog messages generated by the SpeedTouch™ 610:

This page will be refreshed every 30 sec.

Fac	Sev	SysUpTime: 00:00:04 (current time)	Messagecontents
auth	notice	SysUpTime: 00:00:04	LOGIN User logged in on http (10.0.0.3)
kern	err	SysUpTime: 00:00:01	VPN: The Secure Storage is empty
local2	warning	SysUpTime: 00:00:01	DHCP dhcp server up
kern	err	SysUpTime: 00:00:01	VPN: The Secure Storage is empty
kern	info	SysUpTime: 00:00:01	VPN: ID checking enabled.
kern	warning	SysUpTime: 00:00:00	KERNEL Cold restart

This page is every 30 seconds refreshed. Via the CLI you can configure additional syslog events to be notified by syslog messages in addition to the standard set of syslog events.

- Configure a computer IP address to sent the syslog messages to. This allows basic remote monitoring of the SpeedTouch™ 610:

Facility	Severity	Destination
all	debug	10.0.0.3

Facility: Severity: Destination:

For more information, see the application notes “SpeedTouch™ 610 Operation and Maintenance” and “SpeedTouch™ 610 Remote Management”.

2.3. IP Router Tasks Links

Static Routing Clicking this button pops up the IP Address- and Routing Tables page.

This page allows to:

- Overview or add/delete specific IP address entries for the SpeedTouch™ 610 interfaces:

Intf	Address/Netmask	Point-to-Point	Type	Translation
pppoa	80.200.2.187/32	80.200.2.1	Auto	pat
eth0	10.0.0.138/8	not applicable	Extra	none
loop	127.0.0.1/8	not applicable	Auto	none

IP address properties:

Interface: Translation:

Address/Mask: Point-to-Point:

Buttons: Help, New, Delete, Apply

You can add a static IP address for one of SpeedTouch™ 610's interfaces by clicking New. Specify the IP address, (sub)netmask, whether NATP should be applied on this address or not, and select the interface for which the IP address applies (use eth0 for the Ethernet interface). Click Apply to add the entry to the table. All essential IP routes according to this IP address will be automatically added to the SpeedTouch™ 610 IP routing table.

- Overview or add/delete static IP routes for SpeedTouch™ 610's IP router:

Destination	Source	Gateway	Intf
239.255.255.250/32	10.0.0.138/32	10.0.0.138*	eth0
10.0.0.0/8	10.0.0.0/8	10.0.0.138	eth0
10.0.0.138/32	any	10.0.0.138	eth0
127.0.0.1/32	any	127.0.0.1	loop
255.255.255.255/32	any	10.0.0.138*	eth0
10.0.0.0/8	any	10.0.0.138	eth0
224.0.0.0/4	any	10.0.0.138*	eth0
default	any	10.0.0.138*	eth0

Press delete to remove the selected route, press new to add a route.

Buttons: Help, New, Delete

Routing can be useful in the case of subnetting your local network. You can add a static IP route by clicking New. Specify the destination IP address (use the prefix notation to apply a subnetmask), source IP address, and specify the gateway IP address or select the interface for this route. Click Apply to add the entry to the table.

For more information, see the application note “SpeedTouch™ 610 LAN Management”.

RIP Clicking this button pops up the Routing Information Protocol (RIP) page.

This page allows to:

- Overview or configure the SpeedTouch™ 610's general RIP configuration:

The screenshot shows the 'RIP Configuration' page with the 'RIP Settings' tab selected. The configuration fields are as follows:

Rip status	: On
Rip version	: RIP v2
Default metric	: 1
Update time	: 30 seconds
Timeout time	: 180 seconds
Garbage time	: 120 seconds

Buttons for 'Help' and 'Apply' are visible at the bottom.

Via the RIP Settings tab you can enable/disable the master RIP daemon and specify which RIP version should be used. Additionally you can set the default metric and some RIP timer settings.

- Overview or configure the RIP configuration per interface:

The screenshot shows the 'RIP Configuration' page with the 'RIP Interface' tab selected. It displays a table of interface configurations and a form for editing a selected entry.

Intf	Rip Status	TX Version	RX Version	Auth Mode	Passive	Split Horizon
pppoe	Off	Unspecified	Unspecified	No authorization	Off	On
eth0	Off	Unspecified	Unspecified	No authorization	Off	On

Below the table, a form allows editing the selected entry (pppoe):

Interface	: pppoe	Rip status	: Off
TX version	: Unspecified	RX version	: Unspecified
Authentication mode	: No authentication	Authentication string	:
Passive	: Off	Split horizon	: On

Buttons for 'Help' and 'Apply' are visible at the bottom.

Per interface you can:

- Override the master RIP status (enable/disable)
- Override the master RIP version, separately for receiving and sending RIP messages
- Specify whether authorization is needed or not, and if so the required authorization string
- Specify whether the scope of RIP on this interface should be narrowed to the applicable IP range.

- Define one or more RIP neighbors in case multicast messages can not be sent or received among the network



Do not forget to save your changes to persistent memory by clicking Save All. For more information, see the application note “SpeedTouch™ 610 LAN Management”.

NAPT Clicking this button pops up the Network Address and Port Translation (NAPT) page. This page allows to:

- Overview or add/delete specific static NAPT entries:

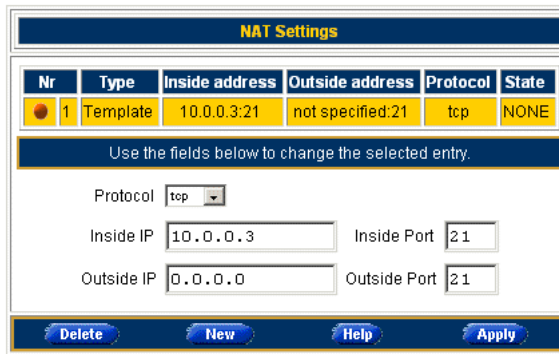

You can add static NAPT entries by clicking New. Specify the outside address and inside address for the entry as well as the protocol and port on which the entry applies. In case the NAPT entry should be applied on a dynamically assigned local peer IP address of a connection, you should specify 0.0.0.0 as outside address. Click Apply to add the entry to the table.

- Define a default server:

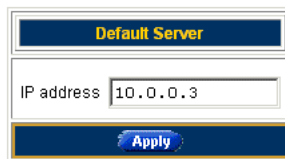

By specifying a default server IP address (e.g. 10.0.0.1 as depicted above) all incoming connections will be forwarded to the device with this IP address. In most cases this setting should be adequate for most server applications and will make the need for specific static NAPT entries redundant.

Do not forget to save your changes to persistent memory by clicking Save All. For more information, see the application note “SpeedTouch™ 610 LAN Management”.

IPSec/VPN

To use the IP Security and IPSec enabled VPN features of the SpeedTouch™ 610, the IPSec VPN software key must be installed. See the topic Add-On in the System Config configuration place for more information, or check the application note “Speed-Touch™ 610 Operation and Maintenance”.

In case IPSec VPN is enabled, clicking this button pops up the IP Security page.

This page allows to:

- Overview the IP VPN configuration setup for the VPN connection:

Peer	IP Address	Local Id	Remote Id	Descriptor
Company_VPN	10.0.0.147	VPN610_home_bepeck	VPN_HQ_bepeck	def_ike

Use the fields below to change the selected entry.

Peer Name: IP Address:

Local Id: Remote Id:

Auth Type: Descriptor:

Secret: Retype Secret:

Buttons: Help, Delete, New, Apply

This window allows to configure the local and remote VPN peer identities, select the key distribution mechanism, and specify in case of a preshared secret, the secret string.

- Overview the VPN connection configuration and start/stop VPN connection sessions:

Connection	Peer	Local Range	Remote Range	Descriptor
Company VPN connect	Company_VPN	10.0.0.0	192.6.11.0	def_auth

Use the fields below to change the selected entry.

Connection Name: Peer Name:

Local Range: Remote Range:

XAuth User: Descriptor:

Password: Retype Password:

Buttons: Help, Delete, New, Apply, Start, Stop

- In case certificates are used for authentication, overview/configure the certificate configuration:

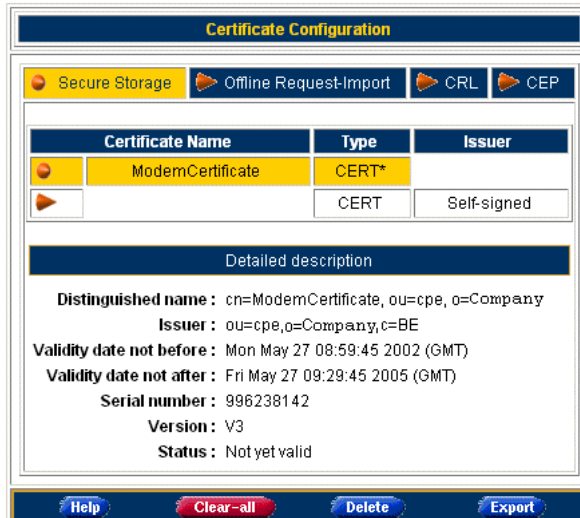

The certificate configuration window contains four tabs, to overview/configure:

- The Secure Storage
- Off-line Request-Import
- Certificate Revocation List (CRL)
- Certificate Enrollment Protocol (CEP)

Following dynamic key distributions are supported:

- Public key infrastructure (PKI) (RFC2459, ITU-T Q.817) with X.509 digital certificates
- On-line PKI enrollment: CEP interoperable with Entrust, Verisign, Netscape and Baltimore CAs
- Off-line PKI enrollment: PKCS#10 “Certification Request Syntax Standard” and PKCS#7 “Cryptographic Message Syntax Standard”, compatible with Entrust, Verisign, Netscape, RSA Security (RSAS) and Xcert.

In case the authentication is based on a shared secret, no certificate configuration needs to be done.

Do not forget to save your changes to persistent memory by clicking Save All.

For more information on the configuration and use of PPP connections, see the application note “SpeedTouch™ 610 IPSec”.

2.4. Connection Tasks Links

Phonebook Clicking this link pops up the Phonebook page.

This page allows to:

- Overview or add/delete ATM Virtual Channels (VCs), that are used for end-to-end connectivity over the DSL line via the Ethernet interface(s):

Phonebook					
Name	Address	Connection Service	AutoPVC	Available	
pppoa	8.35	PPPoA (RFC2364)	Yes	No	
RIETHoA_1	8.41	ETHoA (RFC1483/Br)	No	No	
RyPPPoA	8.44	PPPoA (RFC2364)	No	Yes	
RtPPPoA	8.45	PPPoA (RFC2364)	No	Yes	
CIPOA	8.47	IPoA (RFC1483/RT)	No	No	

Phonebook entry properties:

Name:

Address:

Type: PPPoA (RFC2364)

- Overview the ATM Virtual Channels (VCs), that are used or established automatically for end-to-end connectivity over the DSL line via the 25.6Mb/s ATM-Forum interface (if equipped):

ATMF-ADSL Xconnects			
VPI	VCI	Type	
0	-	user	
1	-	user	

Use the input fields below to add a new entry.

VPI VCI

- Overview the ATM Virtual Channels (VCs) available on the DSL line, detected via AutoPVC:

Auto PVC's		
Type	VPI	VCI
VCC	8	35

For more information, see the application notes “The SpeedTouch™ ATM Services” and “SpeedTouch™ Connection and Packet Services”.

PPP Clicking this button pops up the Routed Point-to-Point Protocol (PPP) page. This page is used to configure both the SpeedTouch™ 610 Routed PPP over ATM (PPPoA) and Routed PPP over Ethernet (PPPoE) Packet Services.

This page allows to:

- Overview/configure the SpeedTouch™ 610 Routed PPPoE and Routed PPPoE Connection entries:

PPP Configuration				
Interface	Destination	Mode	Link	State
pppoa	pppoa	always-on	connected	up

Use the fields below to change the selected entry.

Interface: Destination:

Encapsulation: Protocol:

User: Password:

Per selected Routed PPPoA or Routed PPPoE connection entry, you can:

- If applicable, configure the service name and access concentrator in case of a Routed PPPoE connection entry:

Detailed Configuration

Service:

Access Concentrator:

- If applicable, configure the Routing parameters :

Detailed Configuration

Connection Sharing: Destination networks:

Address translation (NAT-PAT) Specific network:

- If applicable, configure some advanced settings:

Detailed Configuration

Mode: Idle time limit:

Local IP: Remote IP:

Primary DNS: Secondary DNS:

LCP echo (currently enabled)

PAP (currently disabled)

- Overview some statistics in case of a running session:

Detailed Configuration			
PPPoE	ROUTING	OTHER	STATS
IP Address : 217.136.50.119/32		Bytes received : 8215715	
Bytes dropped : 0		Bytes sent : 411545	
Apply		Dial-in	
Hang-Up			

For more information, see the application notes “The SpeedTouch™ Routed PPPoA Packet Service” and “The SpeedTouch™ Routed PPPoE Packet Service”.

MER

Clicking this button pops up the Routed Ethernet page. Routed Ethernet is often referred to as MAC Encapsulated Routing or MER.

This page allows to:

- Overview/configure the SpeedTouch™ 610 Routed Ethernet connection entries:

MER Settings				
Intf	Address	State	Encap	FCS
mer5	mer5	connected	LLC/SNAP	NO

Use the fields below to change the selected entry.

Interface: mer5 Address: mer5

Encapsulation: LLC/SNAP

IP Address: not specified NAT:

IP Netmask: not specified DHCP:

MAC Address: 00:90:D0:01:88:2D

Delete New Help Apply

For more information, see the application note “The SpeedTouch™ Routed Ethernet Packet Service”.

IPoA Clicking this button pops up the Routed IP over ATM (IPoA) page.

This page allows to:

- Overview/configure the SpeedTouch™ 610 Routed IPoA connection entries:

Intf	Address	State	Encap
ipoa1	ipoa1	connected	LLC/SNAP

Use the fields below to change the selected entry.

Interface: Destination:

Encapsulation:

Local IP: NAT:

Remote IP:

Destination Net IP:

Buttons: Delete, New, Help, Apply

For more information, see the application note “The SpeedTouch™ Routed IPoA Packet Service”.

CIP Clicking this button pops up the Classical IP (CIP) over ATM page.

This page allows to:

- Overview/configure the SpeedTouch™ 610 IP interface connection entries:

Intf	Local Address	Mask
cip0	192.6.11.101	255.255.255.0

Use the input fields below to change the selected entry:

Local IP Address:

Mask:

Buttons: Delete, New, Help

- Overview/configure the SpeedTouch™ 610 CIP connection entries:

Nr	Dest	Remote Address
1	CIP1	192.6.11.150

Buttons: Delete, New

For more information, see the application note “The SpeedTouch™ Classical IPoA Packet Service”.

Bridging Clicking this button pops up the Bridged Ethernet page. Bridged Ethernet is commonly known as IEEE802.1D Transparent Bridging or RFC1483/Bridged.

The Bridged Ethernet Packet Service is also used for the Bridged PPP over Ethernet (PPPoE) Packet Service.

This page allows to:

- Overview/configure the SpeedTouch™ 610 Bridged Ethernet connection entries:

Bridging Ports					
Intf	Address	State	Port	Encap	FCS
 Bridge1	Bridge1	connected	wan0	LLC/SNAP	NO

Bridge data Help Delete New

For more information, see the application notes “The SpeedTouch™ Bridged Ethernet Packet Service” and “The SpeedTouch™ Bridged PPPoE Packet Service”.

PPTP Clicking this button pops up the Relayed PPPoA page. Relayed PPPoA is often referred to as PPPoA-to-PPTP Relaying or PPPoA/Point-to-Point Tunnelling Protocol (PPPoA/PPTP).

This page allows to:

- Overview the current active SpeedTouch™ 610 Relayed PPPoA connection sessions:

Active PPTP Connections						
Dial-string	Destination	Qos	Encap	HDLC framing	State	User
-	RyPPPoA	default	VCMUX	never	CONNECTED	10.0.0.1

For more information, see the application note “The SpeedTouch™ Relayed PPPoA Packet Service”.

2.5. LAN Services Tasks Links

DHCP Clicking this button pops up the Dynamic Host Configuration Protocol (DHCP) page. This page allows to:

- Enable/disable the SpeedTouch™610 (Auto)DHCP server:

The SpeedTouch™610 features a DHCP server which allows the PCs/computers on your local network to automatically obtain an IP address (select DHCP Server). In case no DHCP is used on your local network, the SpeedTouch™610 DHCP server can be disabled (select No DHCP). The SpeedTouch™610 is furthermore able to probe your local network for another DHCP server (select AutoDHCP). If so, it slips into DHCP client mode, if not the SpeedTouch™610 becomes DHCP server. Click Apply to apply your selection.

- Configure the SpeedTouch™610 DHCP server lease pool properties:

Pool	Start IP	End IP	State	PPP
LAN_private	10.0.0.1	10.0.0.254	static	-

The SpeedTouch™610 DHCP server (if enabled) will use the address pools listed in this table to provide IP addresses to requesting DHCP clients. To configure a user-defined IP address pool (appropriate to your local network conditions) click New and provide all needed information. Click Apply to add your entry to the table.

- Overview the current leases the SpeedTouch™610 DHCP server supplied to DHCP clients:

DHCP Server Lease					
Lease	Client ID	Address	Pool	TTL	State
1	01:00:01:02:98:18:bf	10.0.0.1	LAN_private	01:59:20	used

DHCP server pool properties:

Address pool LAN_private

Client ID

Address

[Help](#) [Delete](#) [New](#)

Via this table you can also manually add static DHCP leases for specific hosts, if applicable.

- Overview the current SpeedTouch™610 DHCP client status :

DHCP Client Configuration			
Intf	Address	State	Timeout
eth0	10.0.0.1	bound	01:59:59

DHCP client properties:

Interface eth0

Address

Client ID

Host name

Lease time

Address translation (NAT/PAT)

[Help](#) [Delete](#) [New](#) [Renew](#)

Via this table you can also manually add static SpeedTouch™610 DHCP client entries for specific interfaces, if applicable.

For more information, see the application note “SpeedTouch™610 LAN Management”.

DNS Clicking this button pops up the Dynamic Name System (DNS) page.

This page allows to:

- Overview and/or supply the SpeedTouch™610 DNS domain name and to enable/disable the SpeedTouch™610 DNS server:

DNS server configuration	
Server active	<input checked="" type="checkbox"/>
Domain name	<input type="text" value="lan"/>

[Help](#) [Apply](#) [Undo](#)

The use of DNS subdomains is supported, e.g. dsl.office.lan.

- Overview the current SpeedTouch™610 DNS server hostname leases:

DNS Hostname Table		
Nr	Hostname	Address
1	SpeedTouch	not specified
2	Sascha2	10.0.0.1

Use the input fields below to change the selected entry:

Hostname

Address

Via this table you can also add static DNS hostname entries.

This may be useful for devices which do not support DNS, e.g. a printer. By adding a name for your network printer, identified by its IP address, you will be able to contact this printer by name rather than by IP address.

For more information, see the application note “SpeedTouch™610 LAN Management”.

2.6. System Config Tasks Links

Initial Setup Clicking this button pops up the Initial Setup page.

This page allows to:

- Configure a user defined IP address and (sub)netmask for the SpeedTouch™610.

Enter the IP address and (sub)netmask in the appropriate fields. Click Apply to apply the changes.

System Setup Clicking this button pops up the System Setup page.

For more information, see the Topic System Setup in section “2.2. Quick Tasks Links” on page 23.

Upgrade Clicking this button pops up the Software- and Configuration Upgrade page.

This page allows to:

- Upgrade the SpeedTouch™610 system software:

Therefore:

Step	Action
1	Make sure no passive software resides on the SpeedTouch™610. If needed click Remove Passive to remove the passive software version.
2	Browse to the location where the SpeedTouch™610 upgrade system software resides. Therefore, click Browse. Note: Upgrade software may be made available from your Service Provider. Contact your Service Provider for more information.

Step	Action
3	<p>Click Upload. As a result the SpeedTouch™610 upgrade system software name will appear in the 'Passive software version' field.</p> <p>Note: Uploading software may take up to four minutes to complete.</p>
4	<p>Click Switch Over. As a result the SpeedTouch™610 will switch the two system software versions, will reboot and come online with the upgrade system software. Saved configurations remain unchanged.</p>

- Backup the current SpeedTouch™610 configuration, restore the SpeedTouch™610 factory defaults, or upload a new configuration file:

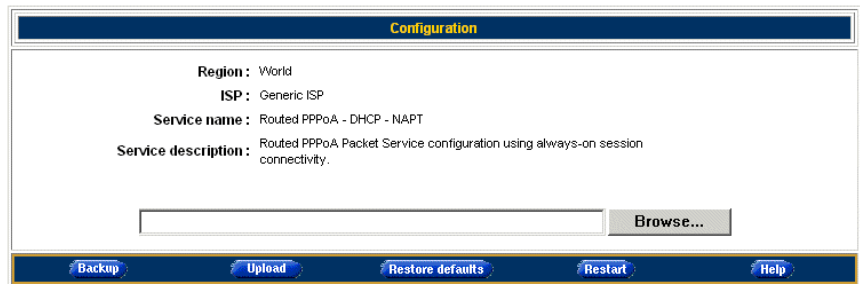

To backup the current configuration, click Backup and follow the instructions.

To restore the SpeedTouch™610 defaults, click Restore Defaults to load the default configuration and Restart to reboot the SpeedTouch™610 and allow the changes to take effect.

To upload a new configuration:

Step	Action
1	Browse to the location where the SpeedTouch™610 upgrade configuration file resides. Therefore click Browse.
2	Click Upload.
3	Click Restart to reboot the SpeedTouch™610 and allow the changes to take effect.

For more information, see the application note “SpeedTouch™610 Operation and Maintenance”.

Add-On Clicking this button pops up the Software Activation Key page.

To use the IP Security and IPSec enabled VPN features of the SpeedTouch™ 610, the IPSec VPN software key must be installed.

This page allows to:

- Overview the current Software module Status:

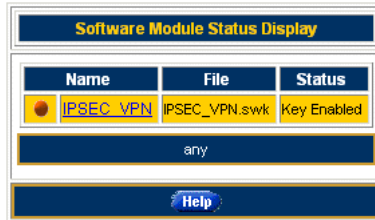

In the example depicted above the software key is installed, hence IP Security and IPSec enabled VPN features are available.

To install the key proceed as follows:

Step	Action
1	Follow the link IPsec_VPN to the SpeedTouch™ software activation key web server.
2	Follow the instructions for generating and downloading the software activation key.
3	<p>If required, paste the obtained software key in the Software Activation Code Input display box:</p> <pre>sdrflkjghsdf1kvjhvlakjhvn;advjhdsf;lkhdmc.,jhdnf.kjzhvm.zfbnz.dkjshfv.ckzjhbmsdkvjmh;dkfhgms.dkfjvbsd.fmkjhdb.kjxfhvb.kdvjhnd.fkjbdxf b dfv/ sl rg;kgav ;o gh 4q[053uhh0auva;ovyqySA\$&YBQ a;z8deh5y;wqv hs:v jq5u bws;ogi jw46iyhd;roitjh;wsjkgc ;whDRDSFVLSKVDERSLVSEGSJSLF^(SDwekjhskwow 09308uvl,ds dlsdgeg oidg1kc====dfg1kj3 e folijgkdkf</pre>
	Note: The key is unique for each SpeedTouch™ 610 device, and can not be copied from/to other SpeedTouch™ devices.
4	Click Add to process the software activation key.
5	Restart the SpeedTouch™ 610. After restart the IP Security and IPSec enabled VPN features of the SpeedTouch™ 610 are enabled. It is not possible to undo a software activation.

For more information, see the application note “SpeedTouch™ 610 Operation and Maintenance”.

SNTP Clicking this button pops up the Simple Network Time Protocol (SNTP) page.

This page allows to:

- Configure an NTP server on the Internet to which the SpeedTouch™ 610 is able to synchronize its internal clock:

SNTP configuration setup : synchronized

The screenshot shows the 'Time Source' configuration page. At the top, there are two tabs: 'SNTP' (selected) and 'Manual'. Below the tabs is a table with three columns: 'IP Address', 'Version', and 'Status'. The table contains one row with the values '129.132.2.21', '1', and 'synchronized'. Below the table, there is a text input field for 'IP address' containing '129.132.2.21' and a dropdown menu for 'Version' set to '1'. At the bottom, there are three buttons: 'Help', 'Delete', and 'New'.

You can check on the Internet for available NTP time servers.

- Overview and/or set the time manually, in case external synchronization is not used:

Time is not controlled by SNTP protocol

The screenshot shows the 'Time Source' configuration page with the 'Manual' tab selected. The page displays a message: 'SNTP has been disabled. Please enter the time and date. Manual settings are lost when the modem is rebooted.' Below the message, there are two input fields: 'Date' with the value '23/05/2002' and 'Time' with the value '13:42:58'. At the bottom, there are two buttons: 'Help' and 'Apply'.

- Overview/configure the regional time settings:

The screenshot shows the 'Timezone' configuration page. It features a dropdown menu for 'Specific timezone' with the value '(GMT+01:00)Brussels, Berlin, Bern, Rome, Stockholm, Vienna'. Below this, there is a 'Daylight saving' field with a dropdown menu set to 'On' and a 'Timezone' field with a placeholder '(+/-hh:mm)'. At the bottom, there are two buttons: 'Help' and 'Apply'.

For more information, see the application note “SpeedTouch™ 610 Operation and Maintenance”.

Syslog Clicking this button pops up the Syslog page.

For more information, see the Topic Syslog in section “2.2. Quick Tasks Links” .

2.7. Advanced Tasks Links

CLI Clicking this button pops up a new web browser page with the SpeedTouch™ 610 Web based Command Line Interface (CLI):

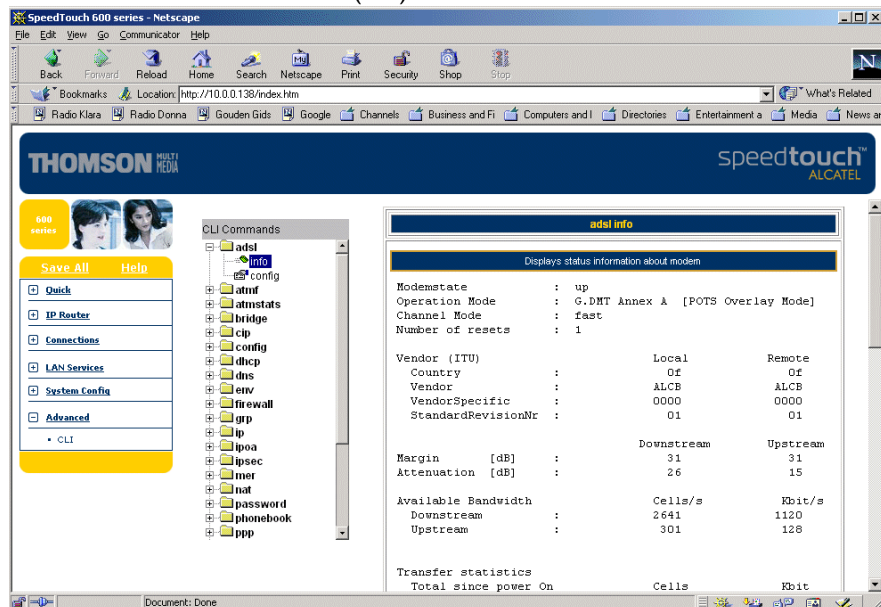

The CLI is meant for in depth configuration of the SpeedTouch™ 610, giving full control on all configurational aspects of the device.

The web based CLI provides the same functionality as the native Command Line Interface, available through a Telnet session to the SpeedTouch™ 610, or via the serial Console interface.

All CLI groups and commands are placed in a menu. You can open a group by clicking the **+** mark next to a group name, or clicking the group name.

Clicking on a command name will execute it. Commands without parameters are indicated with and are executed immediately. Commands which require additional parameters are indicated with . After you configured all parameters, simply click Apply to execute the command.

For more information, see section “3.1. Native Command Line Interface Access” on page 46.

Note: To access the web based CLI pages, you need at least Microsoft's Internet Explorer 4.0, or at least Netscape's Communicator 4.06, or equivalent, both supporting Javascript.

3 SpeedTouch™610 Advanced Concepts

Introduction This chapter is intended to introduce some advanced features the SpeedTouch™610 supports.

Overview The following concepts will be briefly described:

- Native CLI access
- SNMP.

Semi-graphical CLI

To use the semi-graphical Command Line Interface, execute 'menu' from the prompt:

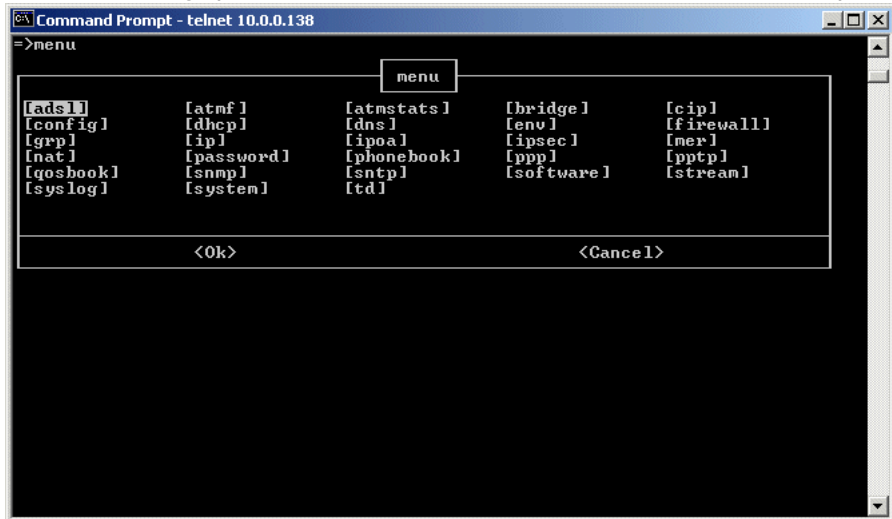

The semi-graphical CLI offers you an attractive and easy-to-use configuration environment for the CLI.

You can browse through the CLI command groups via the arrow keys. Pressing Enter executes your selection. From each level you can execute '..' to go one level up.

Use the Tab key to change from the CLI command menu to the control menu and vice versa.

To setup a CLI command, simply press Enter on its name. You can configure and overview its various parameters at one time. In case the parameter provides preset values, you can go through these via the arrow keys.. If you are satisfied, use the Tab key to go to the 'OK' field and press Enter.

Note: Do not forget to save your changes by executing 'saveall' (from any CLI prompt).

CLI Reference Guide

For a complete description of the SpeedTouch™610 Command Line Interface, see the "SpeedTouch™610 CLI Reference Guide".

3.2. Simple Network Management Protocol

Introduction	The Simple Network Management Protocol (SNMP) is a standard way to retrieve counters, status variables and other diagnostic information of the SpeedTouch™ 610.
SpeedTouch™ 610 MIBs	In the following topics, a short description of the MIBs that are most important to and specific for the SpeedTouch™ 610 is provided.
	Following MIBs are described:
	<ul style="list-style-type: none"> • RFC1213 MIB-II • RFC2864 IF-MIB • RFC2665 Ethernet-like MIB • RFC1493 Bridge MIB • IPSec MIB • RFC2662 ADSL MIB.
MIB-II	MIB-II is the foundational MIB for TCP/IP based Internets. It contains management information and statistics on the IP, ICMP, TCP and UDP protocols.
IF-MIB	The IF-MIB is an extension and replacement of the interface tabel in MIB 2. It contains statistics on the number of bytes and packets transported across the represented interfaces, including errors.
Ethernet-like MIB	The RFC2665 Ethernet-like MIB contains management information on the Ethernet interface. It contains statistics on, for example, alignment errors, collisions and MAC transmission errors.
Bridge MIB	The RFC1493 Bridge MIB contains management information on the Ethernet interface. It contains statistics on, for example, alignment errors, collisions and MAC transmission errors.
IPSec MIB	The IPSec MIB contains management information about the IPSecurity protocols. Details are given of Security associations, Tunnel statistics and errors
ADSL MIB	<p>The ADSL MIB is in fact a bundle of three MIBs: the ADSL-LINE MIB, the ADSL-TC MIB and the PerfHist-TC-MIB.</p> <p>It contains management information about the ADSL interface. It gives details about the ADSL line such as Signal-to-Noise Ratio (SNR), Output Power and Attainable Bit Rate.</p>

4 Troubleshooting

Introduction This appendix provides information on how to identify and correct some common problems you may encounter when using and configuring the SpeedTouch™610.

If the following troubleshooting tips have not resolved the problem contact the company from which you purchased the SpeedTouch™610 for assistance.

Configuration problems

In case you encounter DSL connectivity problems due to misconfiguration you might consider a hardware reset to factory defaults as described in this appendix.

However, be aware that a reset to factory defaults destroys all configurational changes you made to the SpeedTouch™610 internal settings.

Trouble solving table

Problem	Solution
SpeedTouch™ does not work. (none off the LEDs lights up)	Make sure the SpeedTouch™ is plugged into an electrical outlet.
	Make sure the power switch on the SpeedTouch™ is turned on.
No Ethernet connectivity. LAN LED does not light up. Ethernet port(s) link integrity LED does not light up.	Make sure the cable(s) are securely connected to the Ethernet port(s).
	Make sure you are using the correct cable type for your Ethernet equipment.
No ATMF-25.6Mb/s connectivity.	Make sure the (correct) cable is connected to the ATMF-25.6Mb/s port.
	Make sure that the services applied to the computer's ATMF-25.6Mb/s port are appropriate for the service delivered via the DSL line.
Poor SpeedTouch™ performance.	Make sure the SpeedTouch™ is installed as instructed in this User's Guide and/or as instructed by the SP.
	In case of ADSL service, check whether a central splitter or dedicated filters are installed properly.
	In case of SHDSL service, make sure no central splitter or dedicated filters are installed.

Problem	Solution
No Line synchronization achieved. Line Sync LED keeps flashing	Make sure DSL service (ADSL, SHDSL or VDSL) is enabled on the wall outlet your SpeedTouch™ is connected to.
	Make sure the correct SpeedTouch™ variant is used for your DSL service (ADSL, SHDSL or VDSL).

How to perform a hardware reset to factory defaults

Proceed as follows:

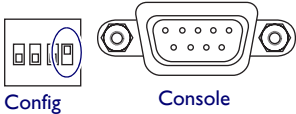
Step	Action
1	<p>Put DIP switch number 4 in the UP position:</p>  <p>You will notice that the PWR/Alarm LED flashes amber.</p>
2	<p>Power cycle the SpeedTouch™610 and wait to allow it to restart. The SpeedTouch™610 will come online with manufacturing defaults.</p>
3	<p>Reset the DIP switch in its original position. If not, the PWR/Alarm LED will flash amber as a warning.</p> <p>Note: Leaving the DIP switch in the UP position, will cause unintended reset to manufacturing defaults !</p>
4	<p>A reset to factory default settings also deletes the configuration profile settings. Therefore, a reconfiguration via the SpeedTouch™ Setup wizard or via uploading the appropriate configuration file might be needed. See section “1.3. SpeedTouch™610 Configuration Setup” on page 11 for more information.</p>

For more information on the operation and management of the SpeedTouch™610, see the application note “SpeedTouch™610 Operation and Management”.

